



***Facility Study for Generation  
Interconnection Request  
GEN – 2002 – 008***

***SPP Coordinated Planning  
(#GEN-2002-008)***

**September 2004**

## Summary

Xcel Energy performed the following study at the request of the Southwest Power Pool (SPP) for SPP Generation Interconnection request Gen-2002-008. The request for interconnection was placed with SPP in accordance SPP's Open Access Transmission Tariff Attachment V, which covers new generation interconnections on SPP's transmission system.

Pursuant to the tariff, Xcel Energy was asked to perform a detailed Facility analysis of the generation interconnection requests to satisfy the Facility Study Agreement executed by the requesting customer and SPP.



**FACILITY STUDY**

**For**

**>TEXT OMITTED<**

240 MW Wind-Generated Energy Facility  
Hansford County, Texas  
SPP #GEN-2002-008

September 16, 2004

Xcel Energy Services, Inc.  
Transmission Planning

## Executive Summary

>TEXT OMITTED< (the “Requester”) requested the interconnection of a wind energy facility to a Southwestern Public Service Company (SPS) 345 kV transmission line. This facility is a new wind energy generation facility located approximately two miles south of the Texas – Oklahoma state line, interconnecting to the 345 kV transmission circuit between Potter County Interchange, in Amarillo, TX and Finney Switching Station in southwestern Kansas. The Southwest Power Pool (SPP) evaluated the request to interconnect this 240 MW wind energy facility to the SPS transmission system in a System Impact Study completed February 10, 2004. This wind energy facility will consist of 131 Vestas V80 wind turbines with a rated output of 1.8 MW each, for a nominal facility output of 235.8 MW.

A new switching station will be constructed that will tap the existing Xcel Energy 345 kV transmission circuit J03 between Potter County Interchange and Finney Switching Station. The new switching station on this transmission circuit is approximately 100 circuit miles from Potter County Interchange. The new switching station will consist of both 345 kV and 115 kV ring buses. A 240 MVA 345/115 kV autotransformer will provide that voltage transformation for the connection of both ring buses, allowing for the transmission of wind energy from the three customer-owned generator collection stations onto the SPS transmission grid. Figure A - 2 shows a one-line diagram of the interconnection facilities.

A Certificate of Convenience and Necessity from the Public Utility Commission of Texas is not required for the construction of the new switching station.

The Requester is responsible for the cost of the Requester’s Interconnection Facilities, inclusive of all construction required for the 115 kV transmission lines from the Requester’s collection substation to the new SPS switching station.

It is anticipated that the construction of the new switching station, for the acceptance of wind generated electric energy from the Requester’s Wind Farm, will require approximately 16 months for completion. The cost of these upgrades, inclusive of the Requester’s cost for the Interconnection Facilities required for the interconnection of this new wind energy generation facility, is shown below:

Stand-alone Network Upgrade:	\$5,651,191
Network Upgrade:	\$801,500
Interconnection Facilities <sup>1</sup> :	\$4,366,188
<u>Total:</u>	<u>\$10,818,879</u>

A detailed description of all costs associated with the construction of this new switching station is shown in Table 1.

An EMTP<sup>2</sup> study (at the Requester’s expense) will be required to determine the final size of the line reactors and the need for neutral reactors. Any changes in the size, type, etc. of these reactors may result in an adjustment to the cost estimates provided in this study.

---

<sup>1</sup> Direct Assigned Cost To Requester

<sup>2</sup> Electromagnetic Transient Program

## Discussion

### General Description of Existing Facilities

The new switching station required to connect the requestor's wind-generated energy facility will be located adjacent to the existing Potter County Interchange to Finney Switching Station 345 kV transmission line. The switching station will be constructed in the southeast corner of Survey 30, Block P, Houston and Great Northern Railway Survey. The new switching station will consist of three breaker 345 kV and four breaker 115 kV ring bus designs, with expansion capability to a breaker and a half configuration. The existing transmission line will be routed in and out of the new switching station with 345 kV breakers on both lines towards Potter County and Finney. Additionally, the customer's 115 kV transmission lines from the three separate collection substations will have 115 kV breakers at the new switching station. Figure A - 2 shows the interconnection one-line diagram for this wind-generated energy facility.

### General Description of Modifications and New Facilities

1. **Construction of New Switching Station:** See Figure A - 3 in Appendix A for one-line diagram and Figure A - 7 for a plan view of the station.
  - 1.1. **Location:** The new 345 kV switching station will be constructed at the interception point to the Xcel Energy transmission circuit J03, located approximately 2 miles south of the Texas–Oklahoma state line on the southeast corner of Survey 30, Block P, Houston and Great Northern Railway Survey. See Figure A - 1 for a map of area.
  - 1.2. **Bus Design:**
    - 1.2.1. The 345 kV ring bus will be built as a 3-breaker ring expandable to a 2 string breaker-and-a-half with 4 lines out. In the Substation there will be two dead-end towers on the 345 kV, 11 switches on structures, three sets of 345 kV potential transformers (PT) on stands, a 345/115 kV transformer with a high-side live tank breaker, and one 345kV PT will be installed on the high-side of the 345/115kV autotransformer.
    - 1.2.2. The 115 kV ring bus is being built as a 4-breaker ring expandable to a 3 string breaker-and-a-half. Additional equipment will include three deadend structures for the four 115 kV gas circuit breakers, four sets of 115 kV PTs and various bus supports. Additional switches will be installed to make future additions possible without requiring bus outages.
  - 1.3. **115 Line Terminals:** The 115 kV line and static wire terminals for the customer-owned 115 kV lines will be designed to accommodate 2,000 pounds per phase conductor at maximum tension, with a maximum 15 degree pull off from normal.
  - 1.4. **Control House:** A control house approximately 24 feet by 36 feet will be installed to contain the metering, protection and control devices, terminal cabinets, and any fiber-optic cable terminations, etc.

- 1.5. **Line Reactors:** Switchable line reactors will be installed at the new switching station to control high voltage. The reactors will be connected to the 345kV lines toward Potter County Interchange and the Finney Switching Station. See Figure A - 3.
- 1.6. **Security Fence:** The switching station will have a 7-foot chain-link fence with steel posts set in concrete, with 1-foot of barbed wire on the top in a "V" configuration. The enclosed area will be approximately 800' x 850', with a rock yard surface.
- 1.7. **Ground Grid:** A complete ground-grid will be installed per ANSI/IEEE STD 80-2000, with our standard 4/0 copper ground mesh on 40-foot centers with ground rods and 20-foot centers in corners and loop outside of fence.
- 1.8. **Site Grading:** Company contractor, per company specifications, will perform initial site grading and erosion control of the new switching station. Soil compaction shall be not less than 95% of laboratory density as determined by ASTM-D-698.
- 1.9. **Station Power:** A 13.2kV/120-240 volt transformer tapped off of the 345/115 kV autotransformer's tertiary winding will provide station power. A backup station power source will be taken from local distribution, if it is available, or a generator will be installed if no distribution service is available. A flip-flop to automatically transfer the station power will be installed.
- 1.10. **Relay and Protection Scheme:** The new switching station to the Potter County 345 kV line relaying will be phase comparison unblocking over power line carrier with a Pulsar TFC10B. A SEL 321-1 and a separate segregated phase comparison transmission line protect system with distance backup protection will be used with a leased phone circuit. An SEL 279H-2 with a SEL 351 relay will be used for sync check and re-closing, along with a SEL 501-0 for breaker failure. The new terminal will preserve the existing capability of high speed single pole tripping.

The new switching station to Finney Switching Station 345 kV line relaying will utilize the same type of equipment as that of the Potter County 345 kV line.

On both the Potter County and Finney Switching Station lines there will be three coupling capacitor voltage transformers (CCVT) for line conditions. Line tuning units and wave traps will also be installed for the power line carrier communications.

The 345/115 kV autotransformer will be switched on the high side with a 345 kV live tank breaker and will have dual differentials with backup protection. The 115kV bus protection that will be provided consists of impedance relays, under/over frequency relays and under/over voltage relays.

The relaying from the new switching station for the 115 kV customer-owned transmission lines will be step distance. A SEL 321-1 and a SEL 311-C will be used. A SEL 279H-2 relay will be installed; however there will not be any automatic re-closing. The SEL 279H-2 will be used for line/bus conditions and sync check along

with supervisory closing of the breaker. Finally, an SEL 501-0 relay will be used for breaker failure.

Two sets of 115 kV PTs will be installed on the north and south buses, with disconnect switches.

The batteries will be our standard set of 306 or 204 AH Varta batteries with a 35 or 25 amp charger.

At Potter County or Finney, carrier frequencies will need to be changed on the existing wave traps and line-tuning units to maintain carrier frequency separation. Additionally, one line terminal may require changing if compatible relays cannot be located.

- 1.11. **Revenue Metering:** On the 115 kV lines from the Requester's collection stations, billing meters will be installed along with an ION 8400 meter unit, ANSI C12.1 accuracy class 0.2 (3 PTs IEEE C57.13 accuracy class 0.3 and 3 CTs IEEE C57.13 accuracy class 0.15) for full 3 phase 4 wire metering. The metering unit will have 1000/600:1 PTs and 200/400:5 CTs. There will be two meters one will be primary and the other will be back-up, and each will have full 4 quadrant metering. Pulses out of the primary billing meter will be sent via SCADA to the Amarillo Control Center.
- 1.12. **Disturbance Monitoring Device:** A disturbance monitoring device will be installed to monitor and record disturbances on the 345kV and 115kV line and equipment.

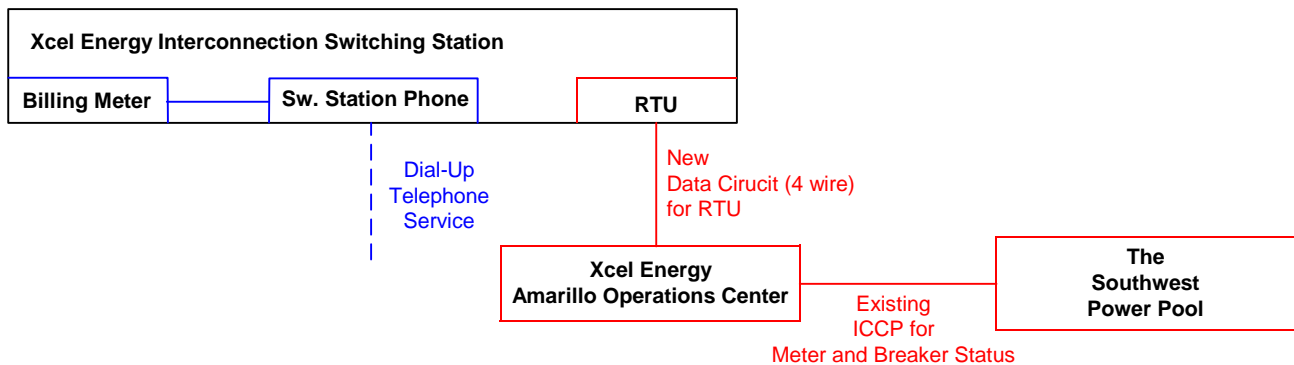
1.13. **Communications:** A high-speed phone circuit will be required between the new switching station and both Potter County Interchange and Finney County substation, which will provide communications for line relaying.

The RTU will be our standard Large 5700 RTU with communications. A SEL 2020 will be installed for relay communications and other functions as required.

Communications from the switching station to the Amarillo Control Center will consist of a 4-wire telephone data circuit provided by the Requester, if it is available. If it is not available, some type of communications will have to be installed, at the Requester’s expense, to get the metering data to the Amarillo Control Center, along with the RTU information.

A station telephone will be installed in the control house. A telephone switch will be installed to transfer between the SEL-2020 and the billing meters along with the station talk service.

A schematic outlining the proposed communications is provided below:



2. **Transmission Line:**

The Requester will construct, own, operate, and maintain the new 115 kV transmission lines from the collection stations to the new switching station. The new 345 kV line taps into the new switching station will be owned, operated and maintained by Xcel Energy.

2.1. **345 kV Line Taps:** An existing Xcel Energy overhead 345 kV transmission line (identified as circuit J03) will be tapped at a southern location as roughly defined by GPS coordinates 36.476133, -101.401921 and extended to the NE to a terminal structure located on the south side of the proposed substation. The length of this tap section, including the span into the substation dead-end tower, is estimated at 3800 feet.

Another overhead tap will be constructed from a northern location as roughly defined by GPS coordinates 36.478872, -101.396464 and extended to the SE to a terminal structure located on the north side of the proposed substation. The length of this tap section, including the span into the substation dead-end tower, is estimated at 2100 feet.



The section of existing 345 kV line between these two tap points will be removed such that power flows in and out of the proposed substation.

See Figure A - 6 for the location of the new proposed line taps.

- 2.2. **115 kV Line Terminations:** The Requester will build the 115 kV lines from the collection stations to the new Switching Station and terminate the lines on our switching station's dead-end steel. All 115 kV transmission lines shall have lightning arresters, which will be interconnection facilities, on Xcel Energy's dead-end tower for protection of the Requester's line. The Requester will provide the dead-end material and the actual dead-ending of the phase conductors and static. There will be an attachment point on the switching station steel for the Requester's dead-end material.

For the phases, the Requester will provide a single tongue two-hole pad for the final jumpers from the 115 kV lines into the new switching station. The attachment point will be a horizontal hole on the ½" thick steel 11/16" in diameter (made for a 5/8" bolt) at a height of 40 feet above our foundations. The maximum tension is 2000 lbs per conductor with a maximum 15-degree pull-off from normal.

For the static, the Requester will dead-end their static to a vertical hole on ½" thick steel 1" in diameter at a height of 55 feet above our foundations. The maximum tension is 2000 lbs per conductor with a maximum 15-degree pull-off from normal.

The 345 kV overhead 3-phase line will utilize double 795-kCMIL conductors per phase in vertical bundle configuration. Two ½" extra high strength steel static wires will provide necessary shielding to the line. The line will be supported by wooden H-frame tangent (in-line structures) and self-supporting steel structures for the angles, corners, and terminations of the line.

See Figure A - 4 for Point of Interconnection and Change of Ownership.

### 3. Right-Of-Way:

- 3.1. **New 345 kV Transmission Line Taps:** Each of the 345 kV transmission line taps will require a 150' wide right-of-way, 75' each side of the power line centerline. See Figure A - 6 for location of line taps.
- 3.2. **New 115 kV Transmission Line:** It will be the Requester's responsibility to perform all necessary tasks associated with the procurement of real estate or right-of-way, inclusive of all surveying, title search, etc., for the Requester's 115 kV transmission line.
- 3.3. **Permitting:** Currently, permitting for the switching station construction is not required in the State of Texas, and the short 345 kV lines into the new switching facility do not require permitting due to their length.

3.4. **Switching Station Location:** Figure A - 5 shows the desired location for this new SPS Switching Station. The new switching station will be constructed at this location assuming the land can be procured from the landowner.

4. **Construction Power and Distribution Service:** Both Construction and Station power, in addition to any distribution service required for the wind-generated energy facility, are the sole responsibility of the Requester. **Xcel Energy, Inc. cannot provide station power (retail distribution service) for the Requester's collection substations if the locations of these collection substations lie outside of the Xcel Energy service area.**

5. **Project and Operating Concerns:**

Close work between the Transmission group, the Requester's Personnel and local operating groups will be imperative to have this project in service on the scheduled date.

**6. Estimated Construction Costs:**

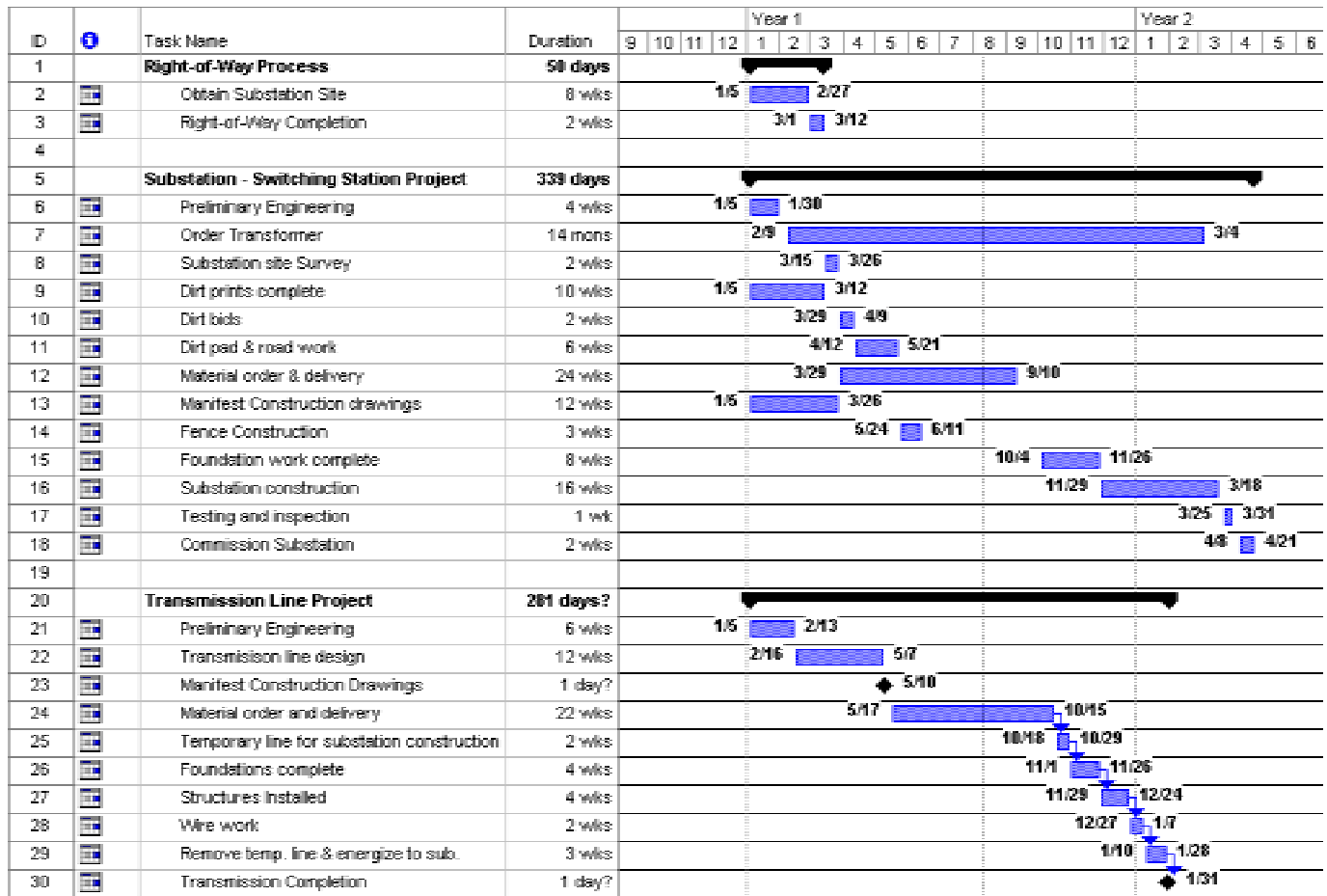
The projects required for the interconnection of the 240 MW wind energy generating facility consist of the projects summarized in the table below:

**Table 1, Required Interconnection Projects**

<b>Project</b>	<b>Description</b>	<b>Estimated Cost</b>
	<b>Stand-alone Network Upgrade</b>	
1	Ring Bus, 345 kV & 25 MVAR line reactors	\$ 5,515,191
2	Right-of-Way Cost (station land, surveying, etc.)	\$ 136,000
	<b>Subtotal:</b>	<b>\$5,651,191</b>
	<b>Network Upgrade</b>	
3	Communications Cost	\$ 85,000
4	Relay Modifications, Potter County and Finney Station	\$ 200,000
5	345 kV Transmission Line Work	\$ 516,500
	<b>Subtotal:</b>	<b>\$801,500</b>
	<b>Interconnection Facilities (at the Requester's Expense)</b>	
6	115 kV Arresters	\$ 12,600
7	Autotransformer 345/115 kV	\$ 2,787,009
8	Ring Bus, 115 kV	\$1,566,579
	<b>Subtotal:</b>	<b>\$4,366,188</b>
	<b>Total Cost:</b>	<b>\$10,818,879</b>

## 7. Engineering and Construction Schedule:

It is anticipated that the switching station and all associated components will be constructed and ready to receive power from the Requester's wind farm approximately 16 months from the day an interconnection agreement is signed, unless prior arrangements have been made. This is the earliest Xcel Energy can initiate the project as a result of other scheduling considerations. An Engineering and Construction schedule is shown below:

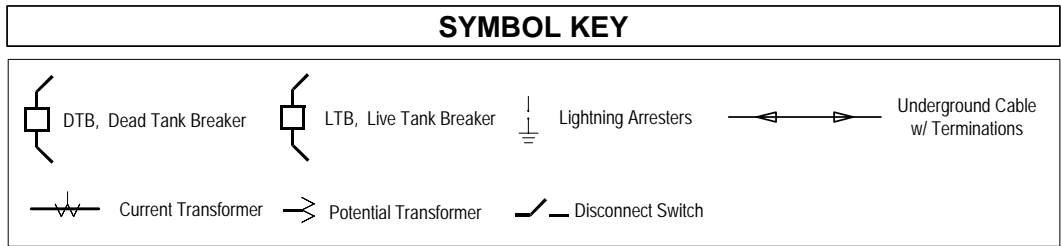
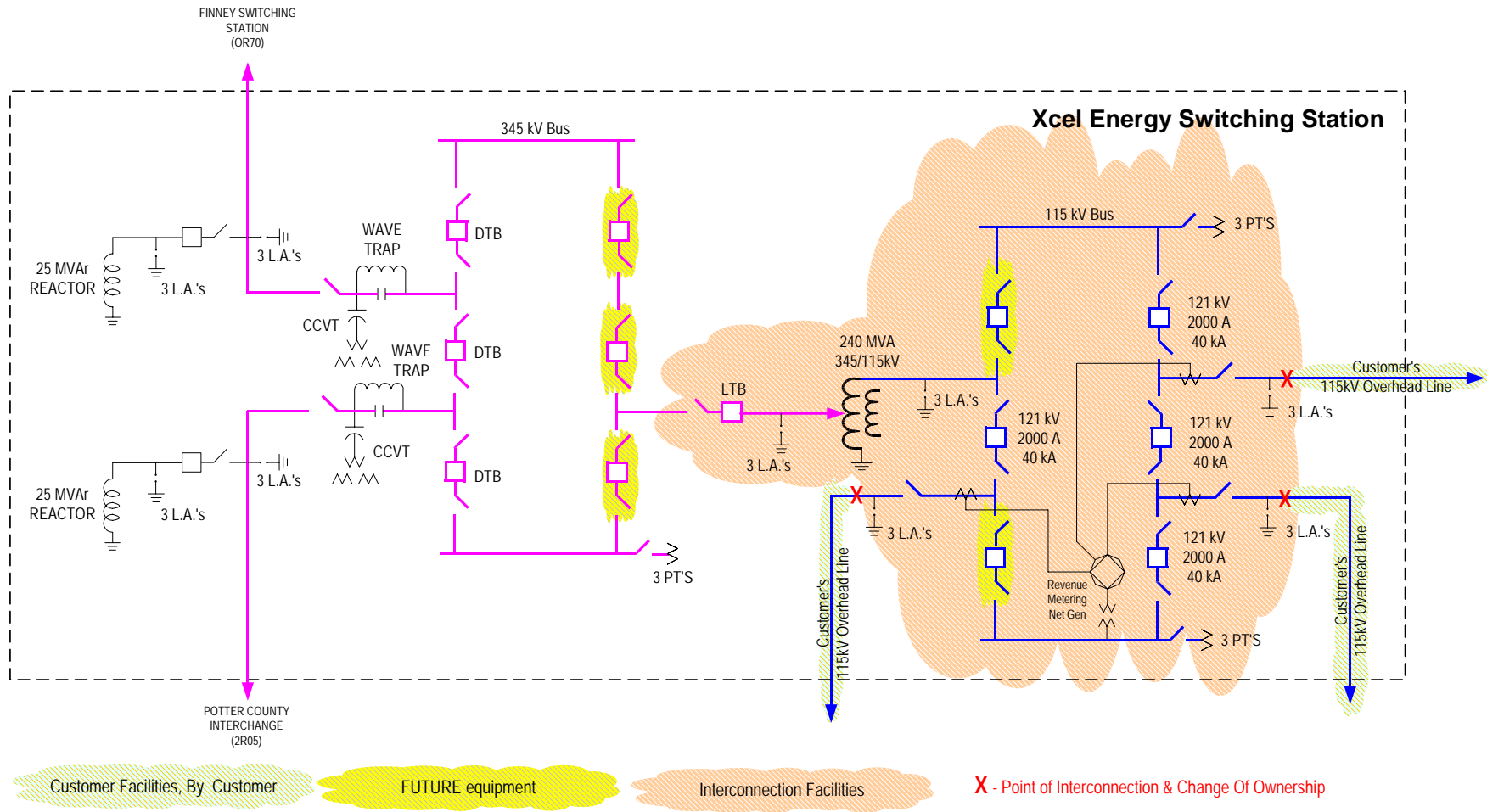


All additional cost for work not identified in this study is the sole responsibility of the Requester unless other arrangements are made.

## Appendix A

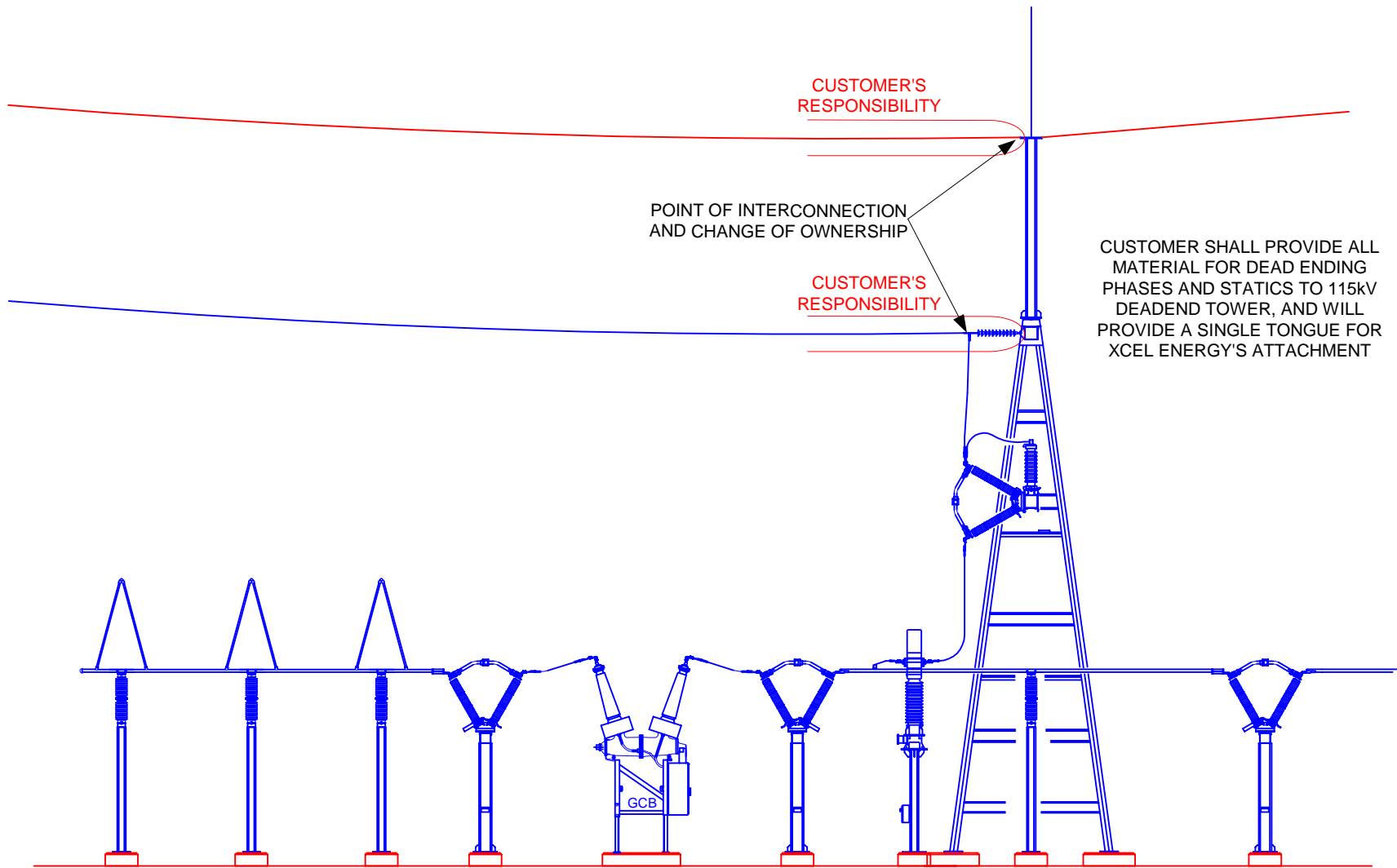




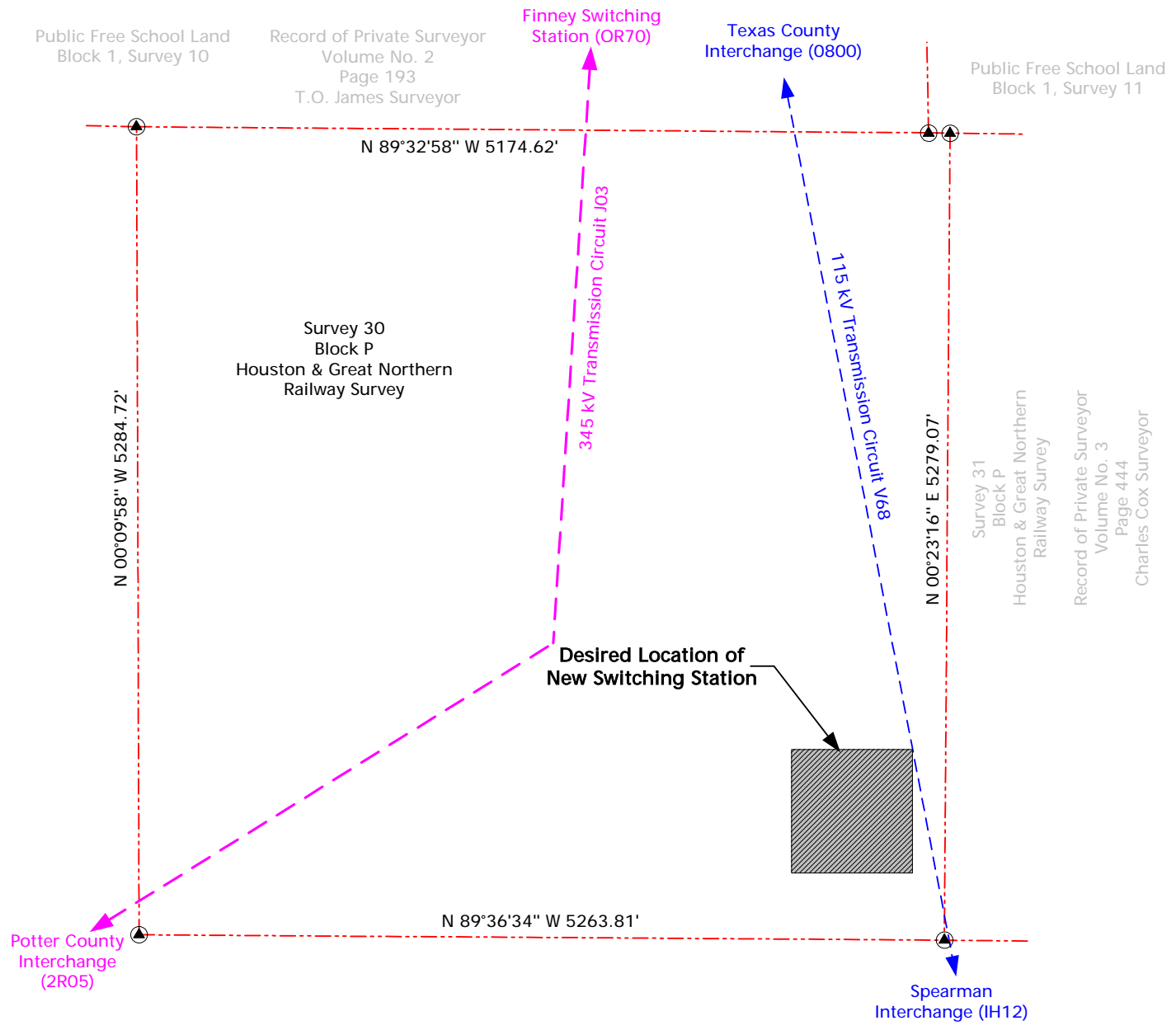


**Figure A - 3 Switching Station One-line Diagram**





**Figure A - 4 Point of Interconnection & Change of Ownership**



**Figure A - 5 Switching Station Location**

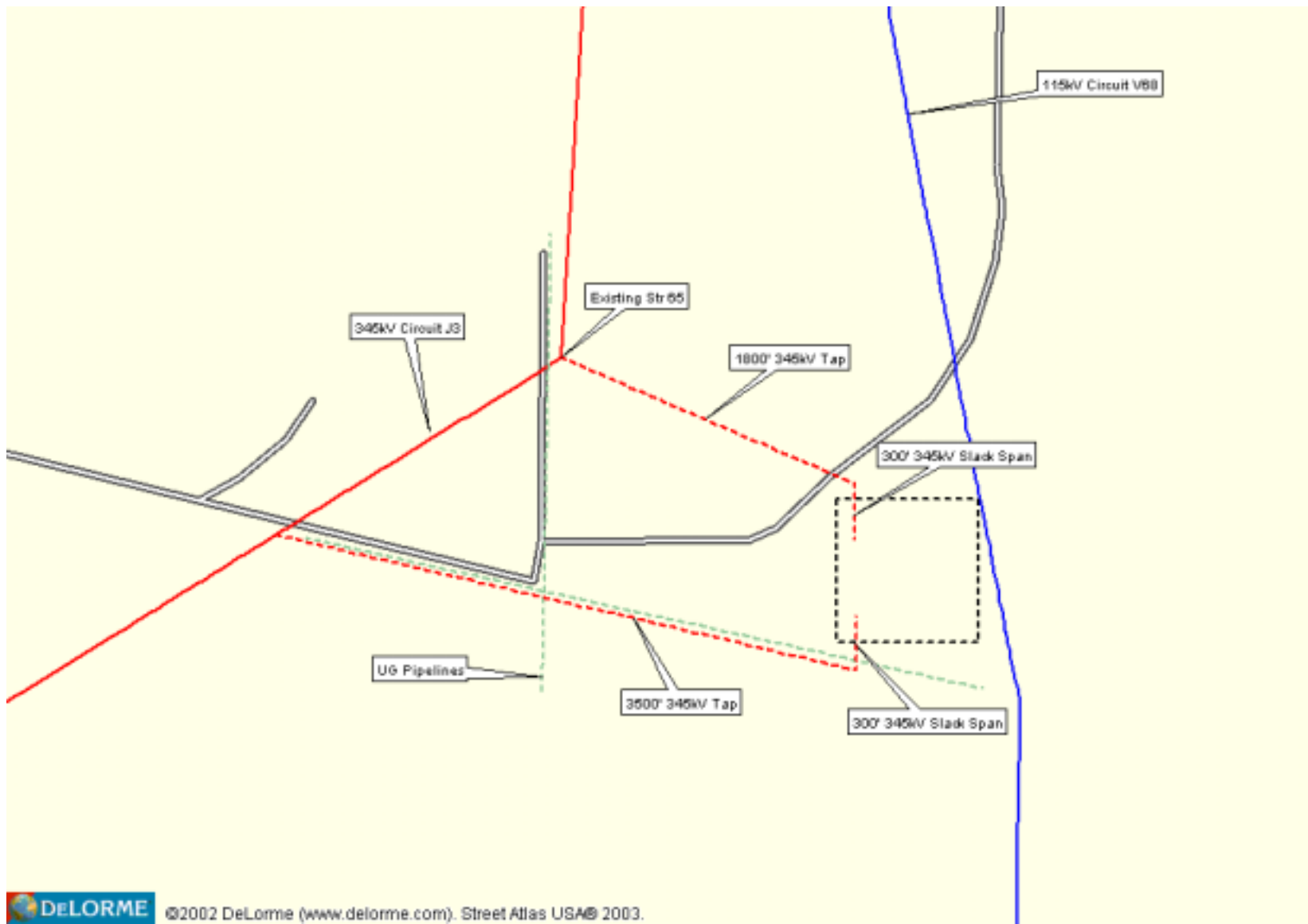
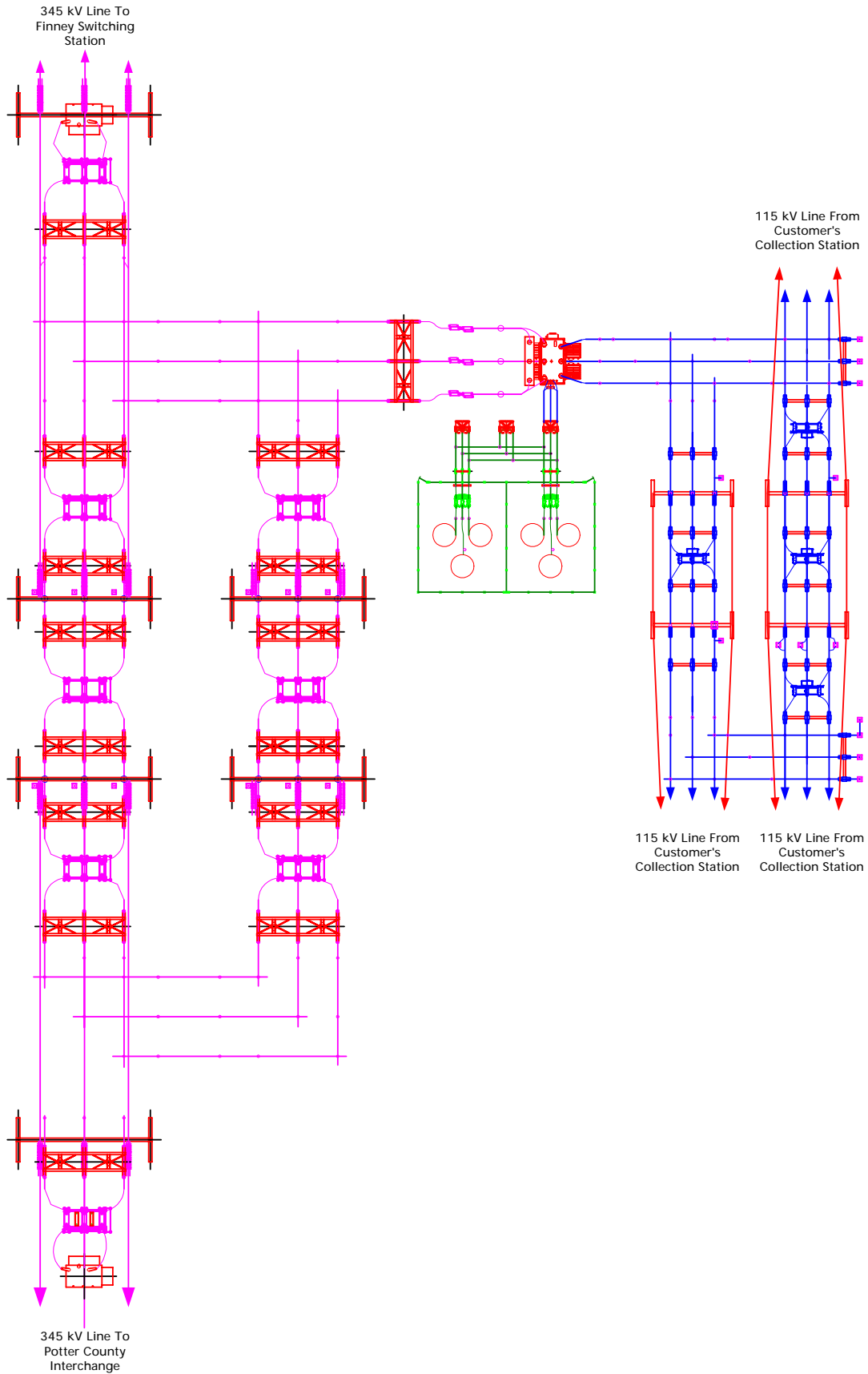


Figure A - 6 Proposed Line Taps on J03



**Figure A - 7 Switching Station Plan View**